



Electrolux

Modular Cooking Range Line 700XP Half Module Gas Lava Stone Grill Top

ITEM # _____

MODEL # _____

NAME # _____

SIS # _____

AIA # _____



Electrolux



Modular Cooking Range Line

700XP Half Module Gas Lava Stone Grill Top

371044 (E7GRGDL00)

700XP HALF MODULE GAS
LAVA STONE GRILL TOP -
LPG/NATURAL GAS

Short Form Specification

Item No. _____

To be installed on open base installations, bridging supports or cantilever systems. Suitable for natural gas or LPG. 7 kW stainless steel gas burners with flame failure device. Gas burners protected by stainless steel deflection trays preventing blockage from foreign objects. Cooking surface grids in cast iron, easily removable for cleaning. Exterior panels in stainless steel with Scotch Brite finish. One piece pressed work top in 1.5 mm thick stainless steel. Right-angled side edges to allow flush-fitting junction between units.

Main Features

- Unit to be mounted on open base cupboards, bridging supports or cantilever systems.
- Heating via Stainless steel gas burners with flame failure device.
- Burners protected by stainless steel deflection trays to prevent blockage.
- Piezo ignition.
- Heavy duty cast iron cooking grids with stainless steel handle to ease removal process
- Cast iron grids can be adjusted on two levels.
- Stainless steel high splash guards on the rear and sides of cooking surface. Splash guards can be easily removed for cleaning and are dishwasher-safe.
- IPX4 water resistance certification.
- Scraper for cleaning of grilling grids included.

Construction

- All exterior panels in Stainless Steel with Scotch Brite finishing.
- One piece pressed 1.5 mm work top in Stainless steel.
- Model has right-angled side edges to allow flush fitting joints between units, eliminating gaps and possible dirt traps.

Optional Accessories

- Frontal handrail, 400mm PNC 216046
- Frontal handrail, 800mm PNC 216047
- Frontal handrail, 1200mm PNC 216049
- Frontal handrail, 1600mm PNC 216050
- Large handrail - portioning shelf, 400mm PNC 216185
- Large handrail - portioning shelf, 800mm PNC 216186
- 2 side covering panels for top appliances PNC 216277
- Scraper for grids with drainage channels - top grills PNC 921614
- Pressure regulator for gas units PNC 927225

APPROVAL: _____



Electrolux

Modular Cooking Range Line 700XP Half Module Gas Lava Stone Grill Top

Front

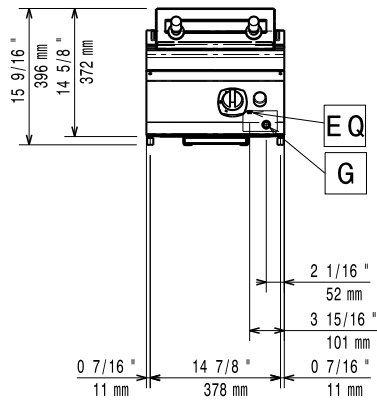

Top

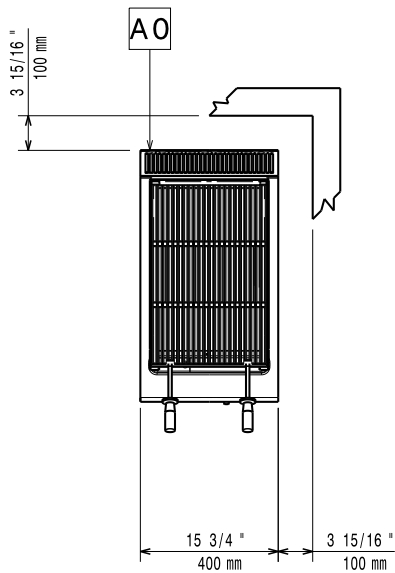

G = Gas connection

Side

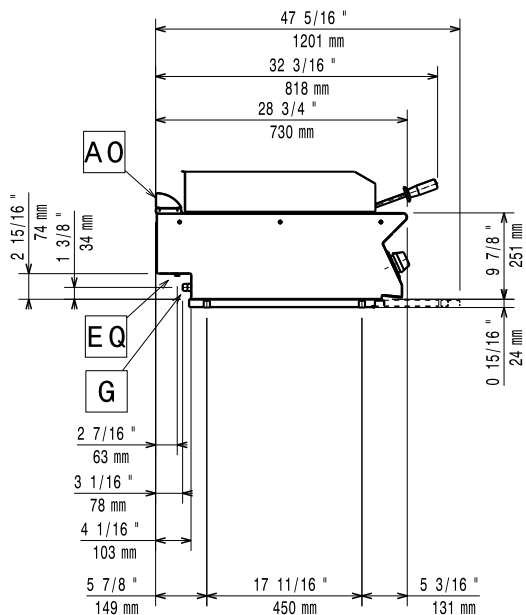

Gas

Gas Power:

371044(E7GRGDL00) 23863 Btu/hr (7 kW)

Gas Type Option:

LPG; Natural Gas; Town

Gas Inlet:

1/2" NPT

Natural gas - Pressure:

7" w.c. (17.4 mbar)

LPG Gas Pressure:

11" w.c. (27.7 mbar)

Key Information:

Net weight:

32 kg

Shipping weight:

39 kg

Shipping height:

540 mm

Shipping width:

500 mm

Shipping depth:

820 mm

Shipping volume:

0.22 m³

If appliance is set up or next to or against temperature sensitive furniture or similar, a safety gap of approximately 150 mm should be maintained or some form of heat insulation fitted.

Modular Cooking Range Line
700XP Half Module Gas Lava Stone Grill Top

The company reserves the right to make modifications to the products without prior notice. All information correct at time of printing.

